

Hawk 3 Digital Panel Meter/Controller



- All parameters set from easy to understand front panel access
- One, two or four 5-amp relays optional
- Five user-selectable brightness levels
- 1/8 DIN, shallow depth case, 3.24"
- RS485 digital communications optional (H345)
- 12 or 24 DCV power supply output optional
- 4-20mA or 0-10 DCV analog transmission optional
- NEMA 4X rated front panel
- DIN Rail adapter available (page C1)

Specifications

DISPLAY	
Type	7-segment, red LED
Quantity	4 or 5
Brightness	5 user-selectable levels
Height	0.56" (14.2mm)
Decimal point	4 or 5 position, user programmable
Overrange indication	Display flashes "EEEEEE" indicating Maximum Value Exceeded
Underrange indication	Display flashes "-EEEE" indicating Minimum Value Exceeded
Alarm Indicators	4 LED indicators for up to four independent setpoints

POWER REQUIREMENTS

AC	120, 85-250 VAC @ 10VA
DC	9-36 DCV @ 10VA

ACCURACY @ 25°C as % of rdg

	4-1/2 digit	3-1/2 digit
DC Current		
High (5A, 2A)	0.2% ± 1 count	0.3% ± 1 count
All Others	0.05% ± 1 count	0.1% ± 1 count
DC Volts		
High (600 V)	0.1% ± 1 count	0.2% ± 1 count
All others	0.05% ± 1 count	0.1% ± 1 count
Resistance		
All ranges	0.1% ± 2 counts	0.1% ± 2 counts
*AC Current		
High (2A, 5A)	0.2% ± 2 counts	0.3% ± 2 counts
All others	0.1% ± 2 counts	0.2% ± 2 counts
*AC Volts		
High (600V)	0.1% ± 1 count	0.2% ± 1 count
All others	0.05% ± 1 count	0.1% ± 1 count

* AC functions measured at 50 Hz, include ± 1 count for each additional 100 Hz above 50 Hz

ENVIRONMENTAL

Operating Temperature	0 to 50°C
Storage Temperature	-10 to +60°C
Relative Humidity	<80%
Ambient Temperature	25°C
Temperature Drift	100 ppm/°C
Warmup time	10 minutes
Noise Rejection	
NMRR	60 dB @ 50-60 Hz
CMRR	70 dB @ 50-60 Hz

A TO D CONVERSION

Technique	Successive approximation with oversampling
Sample Rate	10 conversions per second
Display Rate	User programmable 1-420 updates/min (240 default)

MECHANICAL

Bezel	3.9" x 2.0" x 0.52" (99.8mm x 51.9mm x 13.2mm)
Depth	3.24" (82.3 mm)
Panel cutout	3.62" x 1.77" (92 mm x 45mm)
Weight	10 oz (283.5g)
Cover	NEMA 4X Rated front panel



more >>



Hawk 3 Digital Panel Meter/Controller

Ordering Information

Hawk 3 Indicators can be configured by making an entry into each section. Example: H335-3-71-0-4-1

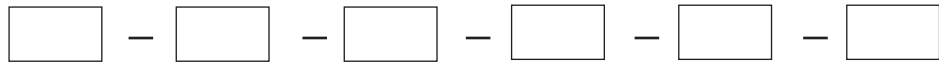

Basic Unit Power Supply Function/Range Output Signal 5A Relay Excitation

Selection	Description	Selection	Description
Basic Unit		Function/Range continued	
H335	3-1/2 digit, Red LED	51	200 ACmV TRMS
H345	4-1/2 digit, Red LED	52	2 ACV TRMS
Power Supply		53	20 ACV TRMS
1	120 ACV (3-1/2 only)	54	200 ACV TRMS
2	85-250 ACV (4-1/2 only)	55	600 ACV* TRMS
3	9-36 DCV	61	200 ACμA TRMS
4	85-250 ACV (3-1/2 only)	62	2 ACmA TRMS
Function/Range		63	20 ACmA TRMS
11	200 DCmv	64	200 ACmA TRMS
12	2 DCV	65	2 ACA TRMS
13	20 DCV	66	5 ACA TRMS
14	200 DCV	71	4-20 DCmA Process
15	600 DCV*	72	0-10 DCV Process
21	200 DCμA	81	200 Ohm
22	2 DCmA	82	2K Ohm
23	20 DCmA	83	20K Ohm
24	200 DCmA	84	200K Ohm
25	2 DCA	Output	
26	5 DCA	0	None
31	200 ACmV	1	4-20 DCmA
32	2 ACV	2	0-10 DCV
33	20 ACV	6	RS-485 (4-1/2 only)
34	200 ACV	5A Relays	
35	600 ACV*	0	None
41	200 ACμA	1	One
42	2 ACmA	2	Two
43	20 ACmA	4	Four
44	200 ACmA	Excitation	
45	2 ACA	0	None
46	5 ACA	1	12 DCV
Continued on next column		2	24 DCV

* Awaiting UL approval

Hawk 3 Temperature Meter/Controller



- All parameters set from easy to understand front panel access
- One, two or four 5-amp relays optional
- 7-segment 4 digit red LED
- Five user-selectable brightness levels
- Activated set point indicators on display
- Min/Max and password lockout
- NEMA 4X rated front panel
- RS485 digital communications output available by special order
- 4-20mA or 0-10 DCV analog retransmission optional
- 1/8 DIN, shallow depth case, 3.24"
- Din Rail Adapter available (page C1)

Ordering Information

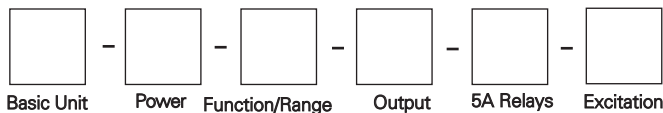

Selection Description Selection Description

Selection	Description	Selection	Description
H340	Basic Unit 4 digit, Red LED	0	Output None
		1	4-20 DCmA
		2	0-10 DCV
1	Power Supply 120 ACV		
3	9-36 DCV	0	5A Relays None
4	85-250 ACV	1	One
		2	Two
91	Function/Range J Thermocouple	4	Four
92	K Thermocouple		
93	RTD, PT100 3-wire	0	Excitation None
94	E Thermocouple	1	12 DCV - 100mA max current
95	T Thermocouple	2	24 DCV - 100mA max current

Specifications

DISPLAY

Type	7-segment, red LED
Quantity	4
Height	0.56" (14.2mm)
Brightness	5 settings, user programmable
Overrange indication	Display flashes "EEEE" indicating Maximum Value Exceeded
Underrange indication	Display flashes "-EEEE" indicating Minimum Value Exceeded

Sensor Break Excitation	Display reads "EEEE" 100mA Max Current
-------------------------	---

POWER REQUIREMENTS

AC	85 to 250 VAC/120VAC @ 10VA
DC	9 to 36 DCV @ 10VA

ACCURACY @ 25°C as % of rdg	Accuracy	Temperature Range
Sensor Type		
RTD Pt 100	0.2% ± 2 counts	-200°C to +200°C
J	0.2% ± 2 counts	-100°C to +760°C
K	0.2% ± 2 counts	-200°C to +1250°C
E	0.2% ± 2 counts	-100°C to +800°C
T	0.2% ± 2 counts	-200°C to +400°C

ENVIRONMENTAL

Operating Temperature	0 to 50°C
Storage Temperature	-10 to +60°C
Relative Humidity	<80%
Ambient Temp	25°C
Temperature Drift	100 ppm/°C ± 0.05 dgt/°C
Warmup time	10 minutes

NOISE REJECTION

NMRR	60 dB @ 50-60 Hz
CMRR	100 dB @ 50-60 Hz

A TO D CONVERSION

Technique	Successive approximation with oversampling
Sample Rate	10 conversions per second
Display Rate	User programmable from 1/minute - 8/second

MECHANICAL

Bezel	3.92" X 2.0" X 0.52" (99.8mm x 51.8mm x 13.2mm)
Depth	3.24" (82.3mm) behind panel
Panel cutout	3.62" x 1.77" (92 mm x 45 mm) 1/8 DIN
Weight	10oz (283.5g)
Cover	NEMA 4X Rated front panel



Panel Cutout Dimensions on page A14

more >>



Hawk 3 Installation Instructions

Installation and Panel Cutout - H335, H340, H345

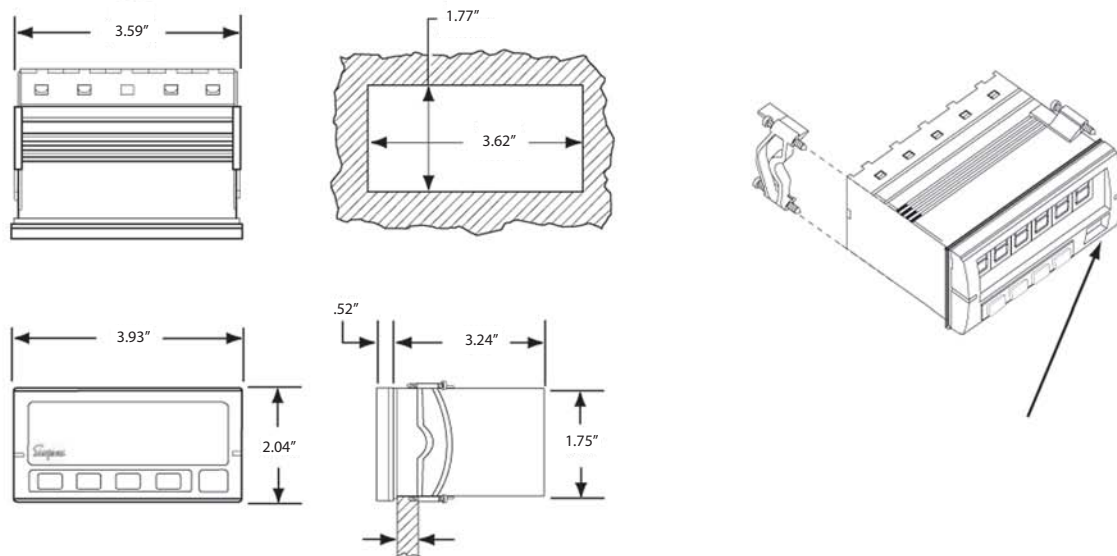

Mounting Requirements

The Hawk 3 Advanced Digital Controller 1/8 DIN meters require a panel cutout of 1.77" (45mm) high and 3.62" (92 mm wide). To install the Hawk 3 meter into the panel cutout, remove the clips from the side of the meter. Slide the meter through the panel cutout, then slide the mounting clips back on the meter. Press evenly to ensure a proper fit. Tighten screws.

Engineering Label Placement

To replace the engineering unit label, place the tip of a ballpoint pen into the small hole at the base of the engineering label in the bezel. Slide the label up until it pops out. Grasp and remove. Slide the new label half the distance in, then use the ballpoint pen to slide it into place.

Inputs

DC Voltage

Range	Resolution 4.5	Resolution 3.5	Input Impedance	Overload
200mV	10µV	.1 mV	1 MΩ	10DCV
2 V	.1mV	1 mV	1 MΩ	100DCV
20 V	1mV	10 mV	2 MΩ	100DCV
200 V	10 mV	.1 V	2 MΩ	300DCV
600 V	.1 V	1V	2 MΩ	1K DCV

DC Current

Range	Resolution 4.5	Resolution 3.5	Input Impedance	Overload
200µA	10 nA	.1 mA	1KΩ	11mA DC
2 mA	.1µA	1 mA	100Ω	35mA DC
20 mA	1µA	10 mA	10Ω	111mA DC
200mA	10 µV	.1 mA	1Ω	353 mA DC
2 A	.1 mA	1 mA	.013Ω	7A DC
5 A	.1 mA	1 mA	.013Ω	7A DC

AC Current

Range	Resolution 4.5	Resolution 3.5	Input Impedance	Overload
200µA	10 nA	.1 mA	1KΩ	11mA AC
2 mA	.1µA	1 mA	100Ω	35mA AC
20 mA	1µA	10 mA	10Ω	111mA AC
200mA	10 µV	.1 mA	1Ω	353mA AC
2 A	.1 mA	1 mA	.013Ω	7A AC
5 A	.1 mA	1 mA	.013Ω	7A AC

AC Voltage

Range	Resolution 4.5	Resolution 3.5	Input Impedance	Overload
200mV	10µV	.1 mV	200KΩ	10DCV
2 V	.1mV	1 mV	200KΩ	100DCV
20 V	1mV	10 mV	2 MΩ	300DCV
200 V	10 mV	.1 V	2 MΩ	300DCV
600 V	.1 V	1V	2 MΩ	1K DCV

Resistance

Range	Resolution 4.5	Resolution 3.5	Input Impedance	Overload
200mΩ	10mΩ	.1Ω	1.2KΩ	± 5DCV
2Ω	.1Ω	1Ω	12KΩ	± 5DCV
20Ω	1Ω	10Ω	121Ω	± 5DCV
200Ω	10Ω	.1Ω	1.2MΩ	± 5DCV